

Kokers en massieve blokken maximaal aanschuinen voor een goede en diepe inbranding

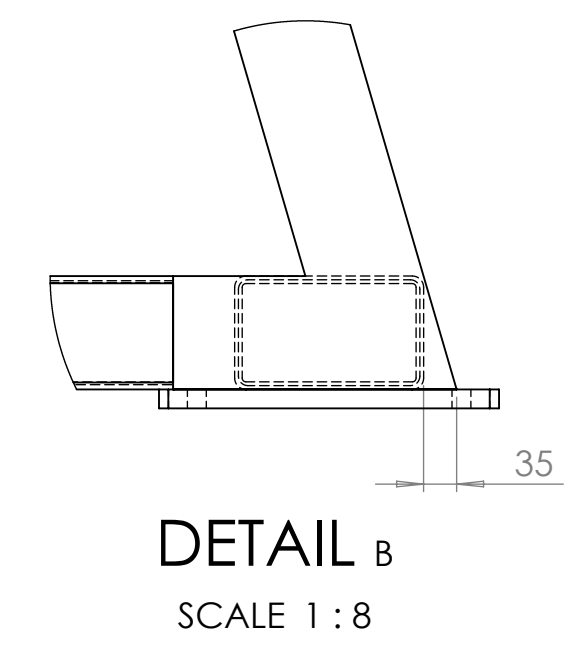
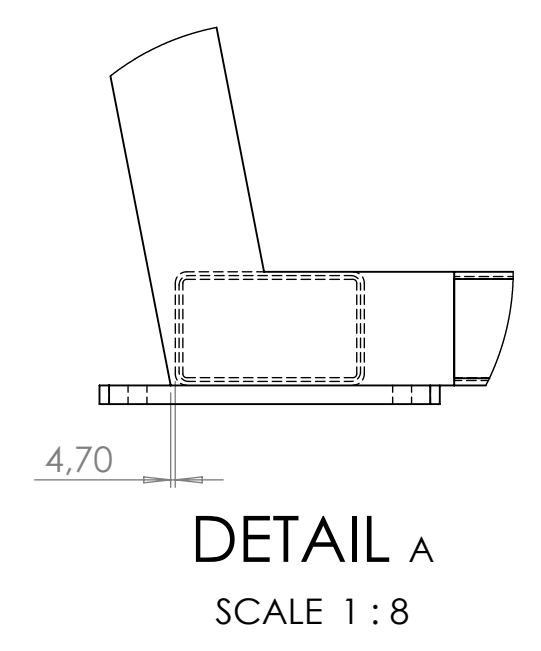
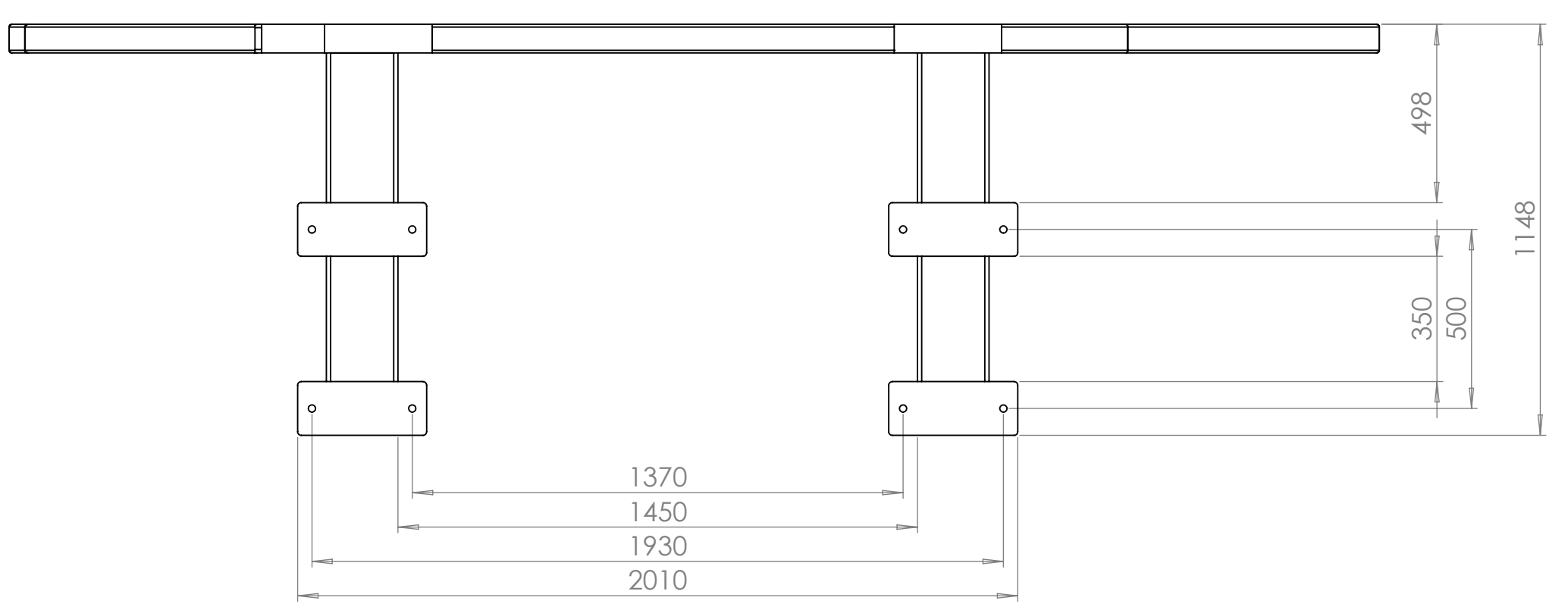

Regel	SW-File Name	Materiaal	Dikte	Aantal	Omschrijving	Langte
11	18-2455-02-04	Fe-37	80	1	Waterstraal snijden	
10	18-2455-01-03	Fe-37	80	1	Waterstraal snijden	
9	18-2455-08	Fe-37	20	4		
8	18-2455-07	Fe-37	10	2		
7	18-2455-06A	Fe-37		2	Koker 200x120x8	1058
6	18-2455-05	Fe-37		1	Koker 120x80x5	1289,7
1	Doos-01			1	Bestaande situatie	

Gewicht Kg		Schaal 1:20	ISO 128
Maattooleranties vlg. NEN-ISO 2768-1		Tolerantieklasse M	
Benaming			
Naam	Datum	Ra in µm	
Getekend	22-6-2018	6.4	
<b>Heurkens &amp; van Veluw B.V.</b> Metaalindustrie Hunedijkstraat 2, 5342 LK Oss tel.: 0412-617224 / fax: 0412-617225			
Tekening no. <b>18-2455-NS-A</b>		REV. A	Sheet 1
		Form. A1	Sheets 1

O:\Unzipped Dxf's\2018\18-2455\Nieuwe tekeningen\18-2455-NS-A